

STAIR-GLIDE

Stairway Lift

MEASUREMENT SHEET-ORDER FORM

INTERMEDIATE, FLAT CURVES & SHORT RADIUS SPIRAL RAILS

DEALER

Date: _____ Dealer #: _____

P.O.# _____

Dealer: _____

Phone: _____ FAX: _____

CUSTOMER

Customer: _____

Job Name: _____

Please indicate any special shipment requests for our consideration Your Order Acknowledgment will provide *estimated ship date*. Please contact your CSR if the Order Acknowledgment differs from your requirements.

Requested Ship Date: _____

Ship on or before Ship on or after

Ship to: _____

- Truck Air
- Prepaid Collect 3rd Party
- Hold and Call, Phone No. _____
- Hold for pickup at terminal

Ship Via: _____

Special Instructions: _____

MISCELLANEOUS

DO NOT manufacture until Production Drawings are approved and returned

Ordered by: _____

Received by: _____

Please fill this order Order confirmation

For Officeuse only

GETTING STARTED: Tools Needed

- 25foot tape measure 3-foot level
- Framing square Plumb line
- Calculator w/ square root key Line level

STEP 1: CONFIGURATION (Select One Drawing Only)

Note: The letter of the configuration matches a measurement diagram on the following pages. If you select an overrun configuration, be sure to complete step 6.

INTERMEDIATE LANDING

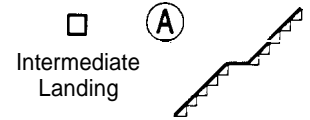

FLAT CURVES

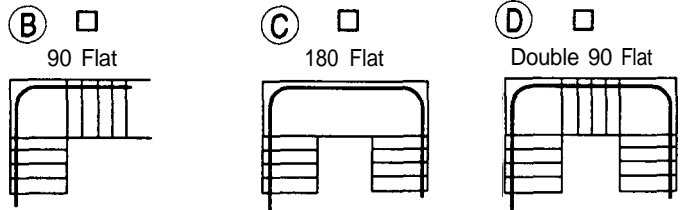

SPIRAL CURVES

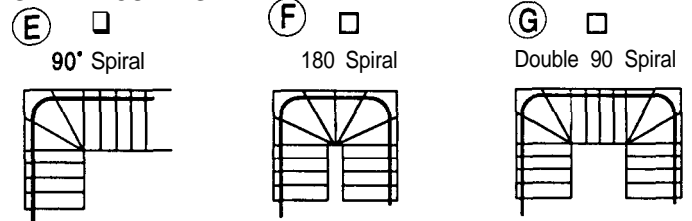

(H) If none of the above configurations matches your stairway, then provide your own sketch on a separate sheet of paper.

STEP 2: ORIENTATION & CUSTOMER APPROVALS

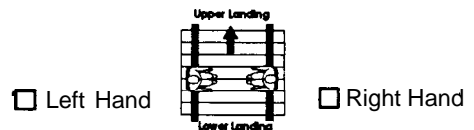

Looking up from the bottom of the stairway

Is this for a residence? _____

If a bannister exists on the side where the rail is to be installed, it may have to be removed. Have you received customer approval to remove it?

Yes No

If the stairway is carpeted, It may have to be cut to properly fasten the rail supports. Have you explained this and received customer approval?

Yes No

If carpet is to remain take all measurements to the carpeting.



STEP 3: TAKING STAIRWAY MEASUREMENTS

- 1) Fill in the measurements for each straight flight on the table to the right
- 2) Use the provided configuration measurement diagrams to record the measurements for each curved flight and/or landings
- 3) Note any obstruction or unusual features of the stairway on the configuration measurement diagrams
- 4) For very unique stairways, it is highly recommended that photographs of the site be taken and mailed with your order form

Before taking any measurements, take a few moments to locate any potential problems areas of the stairway.

- Yes No is there any moulding or stringer along the floor base or stairs?
- Yes No Are there any non-removable protrusions onto the stairway such as window sills, radiators, bannister, fire doors, etc.?
- Yes No Are there any doors at the bottom, middle or top landings of the stairway?
- Yes No Are there any unusual variations of treads or risers on the staircase?
- Yes No in some applications there could be limited headroom clearance. is the headroom clearance less than 78 3/4" (2000mm) at any point on the stairway?

If you answered yes to any of the above questions, sketch them on your configuration measurement diagrams and make detailed notes. Be sure to mark the location of the electrical outlet.

To achieve the "tightest" fit for Stair-Glide rail, it is important that your measurements are taken consistently from one surface (wall, baseboard, moulding, other).

All measurements were taken along (check one):

- Wall
- Baseboard or moulding- (thickness: _____ in. / _____ m)
- Other (describe): _____

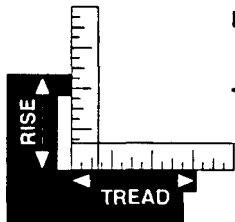

Rise: Height of riser measured vertically from tread nose down to next tread

Tread: Depth of tread measured horizontally from step nose to step nose

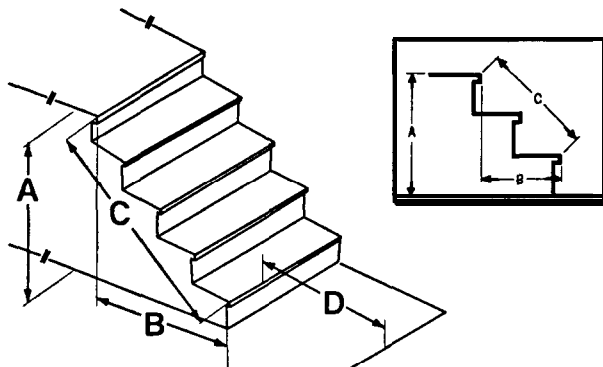

Straight Flights

	For Each Straight Flight:	Straight Flight #1	Straight Flight #2	Straight Flight #3
A	What is the Vertical Height?			
B	What is the Horizontal Length?			
C	What is the Nose-To-Nose?			
D	What is the Clear Distance beyond Bottom Riser?			
	What is the Height of the Bottom Riser?			
	What is the Depth of the Bottom Tread?			
	What is the Typical Height of Other Risers?			
	What is the Typical Depth of Other Treads?			
	How Many Risers are there in each Straight Flight?			
	What is the clear width in each Straight Flight?			

ACCURACY CHECK FOR EACH STRAIGHT FLIGHT

Before leaving the job site, you should CHECK the accuracy of your measurements. The steps are listed below and will only take a few minutes to complete.

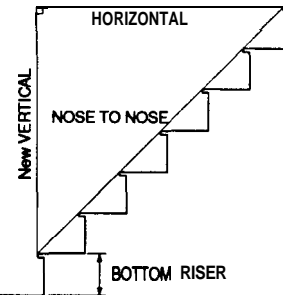

$\sqrt{(\text{Nose to Nose})^2 - (\text{Vertical} - \text{bottom Riser})^2} = \text{Calculated Horizontal}$	
Step	Simplified Formula for In-Field Use
1	_____ Vertical - _____ bottom Riser = _____ New Vertical
2	$\frac{(\text{Nose to Nose})^2 - (\text{New Vertical})^2}{H} = \text{_____}$
3	$\sqrt{H} = \text{_____ (Calculated Horizontal)}$
4	Measured Horizontal _____
5	Enter larger of the two horizontals _____ Enter remaining horizontal _____ $\pm \text{_____}$
NOTE: If result is greater than 2", You MUST recheck your measurements!	

Locate the letter that matches the configuration you chose in step 1 and provide the measurements requested on the diagram. Be sure to measure from the wall (not trim or moulding). Sketch any obstructions or other potential problem areas of the stairway on the diagram.

LABEL THE LOWER LANDING AS "BOTTOM" AND USE AN ARROW TO SHOW WHICH DIRECTION IS UP ON THE DIAGRAM.

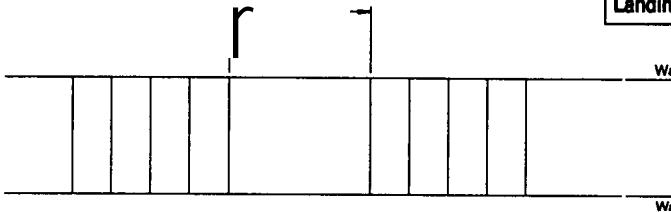
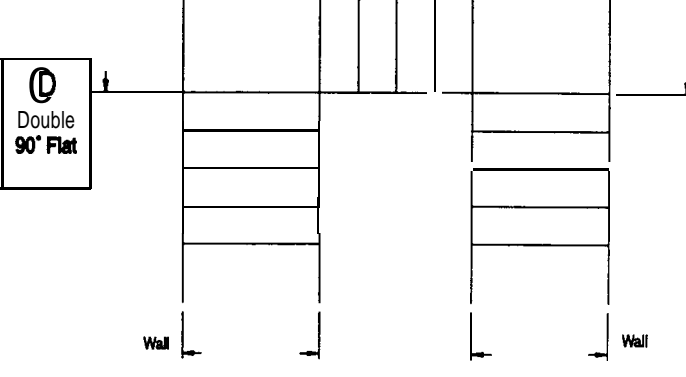
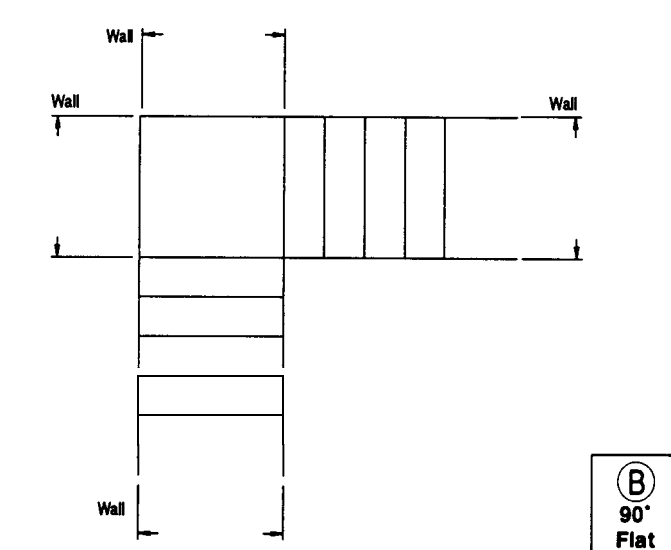
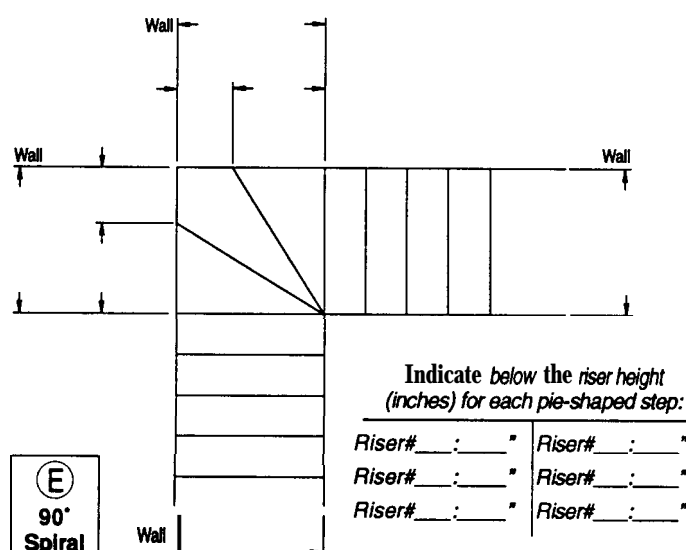
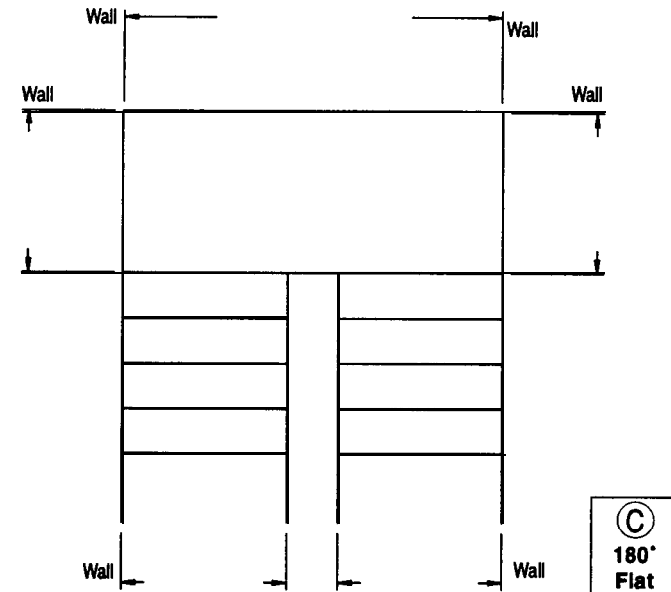
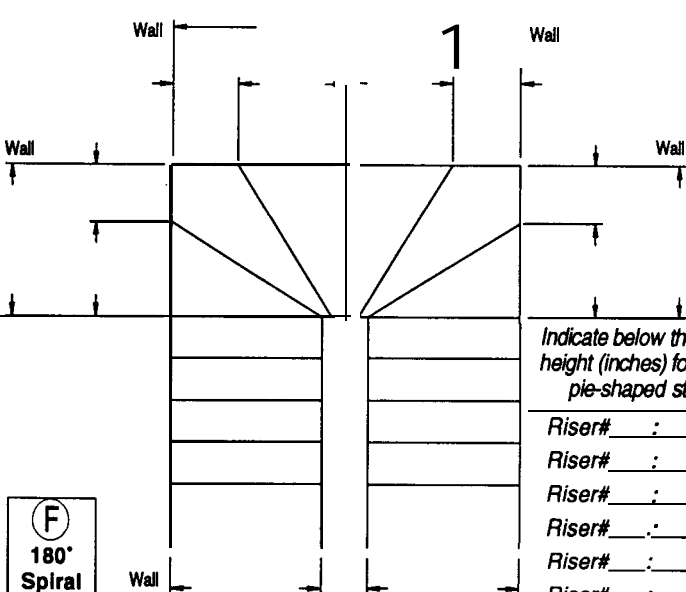
	<div style="border: 1px solid black; padding: 5px; margin-bottom: 5px;"> (A) Inter- mediate Landing </div> <div style="border: 1px solid black; padding: 5px;"> (D) Double 90° Flat </div> 												
	<div style="border: 1px solid black; padding: 5px; margin-bottom: 5px;"> (B) 90° Flat </div> <div style="border: 1px solid black; padding: 5px;"> (E) 90° Spiral </div>  <div style="text-align: right; margin-top: 10px;"> <p>Indicate below the riser height (inches) for each pie-shaped step:</p> <table style="width: 100%; border-collapse: collapse;"> <tr> <td style="width: 50%;">Riser# : : "</td> <td style="width: 50%;">Riser# : : "</td> </tr> <tr> <td>Riser# : : "</td> <td>Riser# : : "</td> </tr> <tr> <td>Riser# : : "</td> <td>Riser# : : "</td> </tr> </table> </div>	Riser# : : "	Riser# : : "	Riser# : : "	Riser# : : "	Riser# : : "	Riser# : : "						
Riser# : : "	Riser# : : "												
Riser# : : "	Riser# : : "												
Riser# : : "	Riser# : : "												
	<div style="border: 1px solid black; padding: 5px; margin-bottom: 5px;"> (C) 180° Flat </div> <div style="border: 1px solid black; padding: 5px;"> (F) 180° Spiral </div>  <div style="text-align: right; margin-top: 10px;"> <p>Indicate below the riser height (inches) for each pie-shaped step:</p> <table style="width: 100%; border-collapse: collapse;"> <tr> <td style="width: 50%;">Riser# : : "</td> <td style="width: 50%;">Riser# : : "</td> </tr> <tr> <td>Riser# : : "</td> <td>Riser# : : "</td> </tr> <tr> <td>Riser# : : "</td> <td>Riser# : : "</td> </tr> <tr> <td>Riser# : : "</td> <td>Riser# : : "</td> </tr> <tr> <td>Riser# : : "</td> <td>Riser# : : "</td> </tr> <tr> <td>Riser# : : "</td> <td>Riser# : : "</td> </tr> </table> </div>	Riser# : : "	Riser# : : "	Riser# : : "	Riser# : : "	Riser# : : "	Riser# : : "	Riser# : : "	Riser# : : "	Riser# : : "	Riser# : : "	Riser# : : "	Riser# : : "
Riser# : : "	Riser# : : "												
Riser# : : "	Riser# : : "												
Riser# : : "	Riser# : : "												
Riser# : : "	Riser# : : "												
Riser# : : "	Riser# : : "												
Riser# : : "	Riser# : : "												

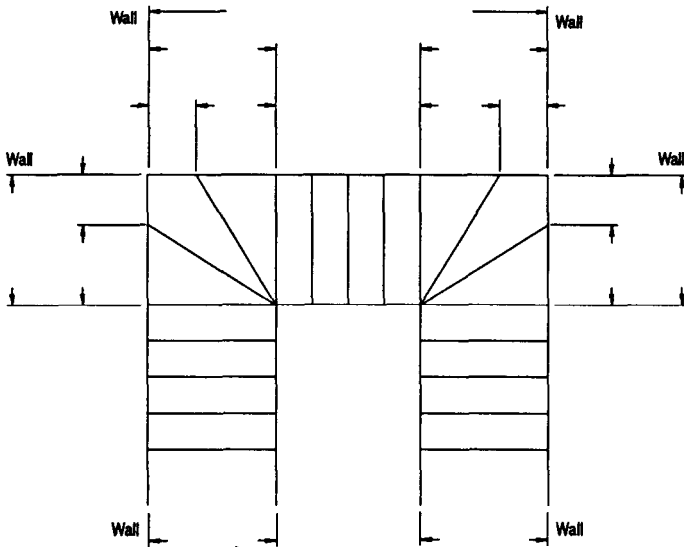

Indicate below the riser height (inches) for each pie-shaped step:

Riser# _____ : _____"	Riser# _____ : _____"
Riser# _____ : _____"	Riser# _____ : _____"
Riser# _____ : _____"	Riser# _____ : _____"



(H) Provide your own sketch on a separate sheet.

STEP 5: TOP EXTENSION (STANDARD)

A to D is the length of the top rail extension and is calculated by Access Industries. It is based on the slope of the stairway and is calculated to put the Stair-Glide seat at the standard seat height for the top landing. The Standard Seat Height is **19"** (483mm) with an A to D measurement of **4"** (102mm), and requires minimum A to H measurement of 5".

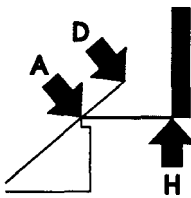

If you want a non-standard seat height, indicate below:

Seat height desired: _____ in.; (_____ mm)

A to H is the measurement of the clearance available at the top landing. If the A to H is less than **5"**, there will not be enough space for the standard seat height. Provide the A to H dimension below if the dimension is less than 5".

A to H dimension: _____ in.; (_____ mm)

STEP 6: TOP & BOTTOM OVERRUN OPTIONS

If you need an overrun at the top, bottom, or both landings, provide the length of the overrun(s) in the spaces below.

Std. top overrun is **24"** (610mm), Std. bottom overrun is **36"** (915mm)

If you require more than the standard overrun, indicate the total length requested in the spaces provided below:

<input type="checkbox"/> Top Overrun: _____ in.; (_____ mm) Std top overrun 24"	<input type="checkbox"/> Bottom Overrun: _____ in.; (_____ mm) Std bottom overrun 36"
--	--

Note: Standard seat height with an overrun is 25:

STEP 8: COLOR SELECTION

STANDARD (Ivory rail & unit with choice of upholstery below):

- | | |
|--------------------------------|--------------------------------------|
| Fabric | Vinyl |
| <input type="checkbox"/> Plum | <input type="checkbox"/> Taupe |
| <input type="checkbox"/> Smoke | <input type="checkbox"/> Misty gray |
| <input type="checkbox"/> Teal | <input type="checkbox"/> Sable brown |
| <input type="checkbox"/> Wheat | |

OPTIONAL

- Sable brown rail, unit & vinyl upholstery
- Special customer selected fabrics. Requires 1 yard by 54" of fabric. Please contact factory.

STEP 9: SELECT OPTIONAL EQUIPMENT

- Wraparound arms, folding
 - Upholstered hand rests for wraparound arms
- Hand-held pendant control
- Final limit switch - top and bottom landing
- Manual lowering device (hand crank)
- Key switch on Call/Send controls and unit
- Overspeed brake
- Outdoor Package
- Public Building Package (key switch on Call/Send and unit controls, overspeed brake and two operation plaques)
- Folding rail (complete below):

- Manual (requires minimum 3 risers)
 - Power (requires minimum 3 risers)
- A to C dimension: _____ in.; (_____ mm)
- B to C dimension: _____ in.; (_____ mm)

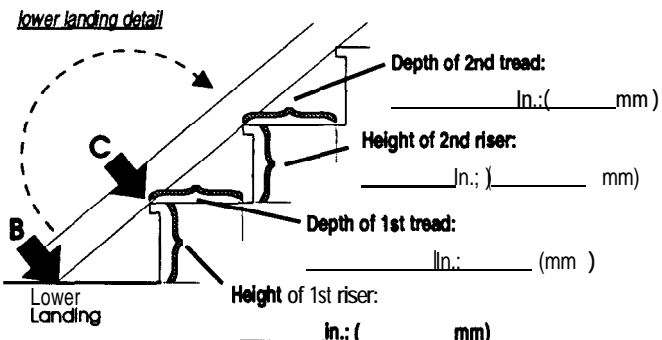

Note: Power folding rail will require rail to be an additional 1" from wall; Manual folding rail with 46° or higher slope requires additional 1" from wall.

Measure the stairway clear width at the narrowest point. (Note: recommended minimum is 32 inches.)

_____ inches